



**Longer Equipment & Fluid Life - Lower Maintenance Costs**

## Magnom® CP (Circuit Protection Units)

Built from Aluminium Alloy or Stainless Steel, the CP is a small 2 core Magnom in-line unit.

The CP has a very high pressure capability making it highly suitable for a variety of industrial and hydraulic applications. In particular it is designed to protect key components, such as valves etc. in fluid circuits.

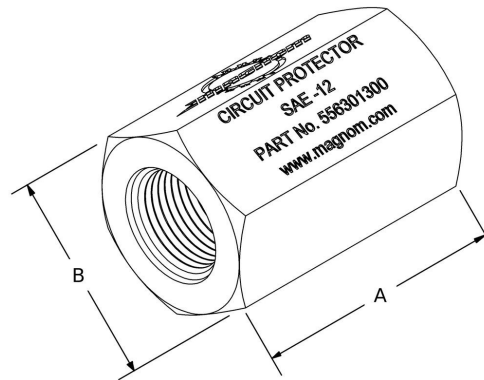

Mounting Method:	In-Line
Flow Direction:	Bi-Directional
Construction Material:	
Housing	Aluminum Alloy or Stainless Steel
Magnet	Samarium Cobalt
Magnom Plates	Carbon Steel
C-Clip	Steel
Max. Operating Temperature: °C/(°F)	150/302

UNIT WEIGHT AND NOMINAL DIMENSIONAL INFORMATION									
Part Number	Unit	Connection / Size	Weight KG / (OZ)	DIM.A CM / (Inch)	DIM.B CM / (Inch)	Head/Body Material	Mandrel Material	Max. OP BAR/ (PSI)	Burst Pressure BAR / (PSI)
556201200	CP-10	SAE-10	0.159 / (5.6)	6.5 / (2.50)	3.5 / (1.37)	Aluminum	Aluminum	276 / (4000)	1104 / (16000)
556201300	CP-12	SAE-12	0.454 / (16)	7.2 / (2.83)	4.5 / (1.75)	Aluminum	Aluminum	276 / (4000)	1104 / (16000)
556301200	CP-10	SAE-10	0.412 / (14.5)	6.5 / (2.50)	3.5 / (1.37)	Stainless Steel	Aluminum	414 / (6000)	1654 / (24000)
556301300	CP-12	SAE-12	0.681 / (24)	7.2 / (2.83)	4.5 / (1.75)	Stainless Steel	Aluminum	414 / (6000)	1654 / (24000)
556301400	CP-16	SAE-16	1.136 / (40)	7.5 / (2.95)	5.7 / (2.25)	Stainless Steel	Aluminum	276 / (4000)	1241 / (18000)
556301501	CP-20	SAE-20	1.68 / (59.26)	9.0 / (3.54)	8.5 / (3.35)	Stainless Steel	Stainless Steel	276 / (4000)	1241 / (18000)

Product Data Sheet : CP (Circuit Protection) Unit

[www.magnom.com](http://www.magnom.com)

[info@magnom.com](mailto:info@magnom.com)

UK Office: tel +44 (0) 1926 623170 fax +44 (0) 1926 623171

USA Office: tel (312) 724 5839